



Cuming County Public Power District

Distributed Generation (DG) Policies and Procedures Manual

A Guide to the Interconnection of
Distributed Generation with the
Electric System of
Cuming County Public Power District

This document is subject to change without notice.
Please contact the Cuming County Public Power District
for the latest requirements

**CUMING COUNTY PUBLIC POWER DISTRICT
DISTRIBUTED GENERATION (DG) INTERCONNECTION**

PURPOSE.....2
SCOPE2
STANDARD.....2
 INTRODUCTION2
 Objective2
 Regulatory Compliance and Interconnection Requirements3
 Responsibility3
 Enforcement.....4
 Rates.....4
 REQUIREMENTS FOR CLOSED TRANSITION OPERATION4
 General.....4
 Periodic Testing5
 CCPPD Access to DG Facility Equipment.....5
 Utility Service Termination Clause6
 Nontransferable Agreements for Change of Ownership or Modified Facilities.....7
 Interconnection Expenses7
 Contact Information8
 CLASSIFICATION OF THE DG INTERCONNECTION.....9
 Class I ‘Type A’ Interconnections10
 Class I ‘Type B’ Interconnections10
 Class II10
 Class III.....11
 Interconnection Point11
 Duration of Parallel Operation.....12
 Power Transfer.....13
 Import-Only, Import/Export or Export-Only13
 THE DETAILED APPROVAL PROCESS FOR DG INSTALLATIONS14
 Description of CCPPD Forms.....14
 Application Process for New Installations.....14
 DG Installation Renewal.....17
 TECHNICAL REQUIREMENTS19
 Overview19
 Power Quality Restrictions for Generation.....21
 Protective Equipment.....23
 Protective Functions\Relaying29
 CCPPD SYSTEM REQUIREMENTS.....31
 Metering and Telemetry Equipment Metering31
 Telemetry33
 Service Transformers33
 Automatic Reclosing.....34
 ATO Service35

Single-Phase Devices.....	35
PRE-PARALLEL REQUIREMENTS	36
CCPPD Agreement for Closed Transition Operation of Distributed Generation.....	36
Engineering Drawings	36
Final Documentation.....	36
REFERENCES	38

PURPOSE This document is an administrative and technical standard that specifies the requirements of the Cuming County Public Power District (CUMING COUNTY PPD) for the interconnection of Distributed Generation (DG) facilities to the CUMING COUNTY PPD system. The primary objective of this standard is to ensure a safe, efficient, and consistent approach for all interconnections.

SCOPE Applies to CUMING COUNTY PPD customers inquiring about the interconnection of DG facilities to the CUMING COUNTY PPD system. This standard also applies to all internal employees when working with such facilities.

STANDARD INTRODUCTION

Objective

The requirements stated in this standard are applicable for all DG facilities operated in parallel (also known as closed transition) with the electrical subtransmission and distribution facilities owned and/or operated by CUMING COUNTY PPD. In most cases, CUMING COUNTY PPD requirements will be consistent with the latest version of IEEE P1547 ‘Standard for Interconnecting Distributed Resources with Electric Power Systems’.

The interconnection requirements of this standard do not apply to generation that is physically and mechanically incapable of closed transition operation (parallel operation) with the utility. A traditional emergency engine-generator installed with an open transition automatic transfer switch is an example of equipment for which the requirements of this standard do not apply.

NOTE: All open transition switchgear (either automated or manual via a transfer switch) capable of closed transition operations must meet NEC requirements and must be installed by a qualified licensed electrician.

These requirements are intended to achieve the following:

- Ensure the safety of the general public and CUMING COUNTY PPD personnel.
- Minimize possible damage to the property of the general public, CUMING COUNTY PPD customers, and CUMING COUNTY PPD's system.
- Permit the DG facility Owner (or 'Owners') to install and operate generating equipment in parallel with the CUMING COUNTY PPD electric system in a manner that is safe and reliable.
- Minimize adverse operating conditions on the CUMING COUNTY PPD electric system.

CUMING COUNTY PPD reserves the right to revise this standard at any time, and the DG facility Owner must comply with any such revised standard.

Regulatory Compliance and Interconnection Requirements

It is the responsibility of the DG facility Owner to obtain any and all permits and jurisdictional approvals and to comply with all applicable codes.

The Owner needs to work closely with CUMING COUNTY PPD to keep up-to-date on the interconnection requirements.

The requirements to interconnect generation vary depending upon:

- The interconnection voltage
- Direction of power flow at the interconnection
- Classification of the proposed generation

CUMING COUNTY PPD requires a professional electrical engineer to certify drawings, tests, settings, or other documentation. The professional engineer's seal must be valid for the state in which the project is being constructed.

This standard does not provide specific interconnection expense cost data to the DG facility Owner. As proposed, DG facilities must be evaluated on a case-by-case basis. CUMING COUNTY PPD will examine the impact of a proposed facility and evaluate costs for CUMING COUNTY PPD's system modifications, DG facility service modifications, or other required action during the 'application' phase. Specific interconnection expense cost data will be addressed during this process.

Responsibility

The application process described in this standard concludes with CUMING COUNTY PPD approving or disapproving a parallel generation

interconnection. Prior to issuing its decision, CUMING COUNTY PPD will complete an engineering and operational review of the interconnection to ensure the system will be protected and can be maintained and does not anticipate other CUMING COUNTY PPD customers will be adversely affected by operation of the parallel generation.

CUMING COUNTY PPD is not liable or responsible for DG Owners equipment or the DG facility electrical system (or the protection of either). The DG facility Owner is solely responsible for protecting its equipment to prevent damage from faults, imbalances, out-of-phase reclosing, or other disturbances on the CUMING COUNTY PPD system. Additionally, the DG Owner will be responsible to protect CUMING COUNTY PPD property, public safety, and CUMING COUNTY PPD personnel due to failure of the DG system.

Enforcement

By entering into the process of obtaining approval of the parallel generation of its DG facility from CUMING COUNTY PPD, the DG facility Owner agrees to comply strictly and completely with all requirements of this standard and all applicable laws, regulations, and industry codes related to the DG facility. CUMING COUNTY PPD will be entitled to enforce the requirements of this standard and to obtain relief from any breach by the DG facility Owner of its requirements in any manner provided by law and will be entitled to all available remedies, including money damages and equitable relief.

Rates

CUMING COUNTY PPD rates for electric service are/or will be established in CUMING COUNTY PPD rate schedules. The DG Owner should obtain and review current copies of CUMING COUNTY PPD's applicable Rate Schedules for DG.

REQUIREMENTS FOR CLOSED TRANSITION OPERATION

General

Any operation of generation in closed transition with CUMING COUNTY PPD system requires a signed and executed 'CUMING COUNTY PPD Agreement for Closed Transition Operation of Distributed Generation' between CUMING COUNTY PPD and the DG Owner and Owner's receipt of 'Application For CUMING COUNTY PPD Approval To Construct Distributed Generation (DG) Interconnection'. Prior to execution of the agreement, the DG Owner must have obtained a CUMING COUNTY PPD-approved 'Application for CUMING COUNTY PPD Approval to Construct DG Interconnection'. The installation must be inspected and approved by CUMING PPD for parallel

operation. Parallel operation without a signed agreement, or failure to comply with the terms of the agreement, may result in termination of the utility service.

Upon review of the DG applicant's design for the proposed parallel installation, CUMING COUNTY PPD may require changes to the protection scheme, interconnection point, or other items. CUMING COUNTY PPD will notify the applicant, in writing, of approval of the 'Application for CUMING COUNTY PPD Approval to Construct DG Interconnection'. The applicant should not release DG equipment for manufacture or begin installation of DG equipment until this approval has been received.

Periodic Testing

See 'Protective Equipment' in this standard for testing and verification schedules for protective equipment.

CUMING COUNTY PPD requires periodic testing and verification of all DG-utility interconnections. The test(s) will verify the interconnection functions as originally approved by CUMING COUNTY PPD. The interconnection equipment will be tested for conformity with the initial 'as installed' test requirements, and per all requirements of IEEE 1547 Series of Standards.

Except where exempted by CUMING COUNTY PPD, the testing/results must be certified by a Professional Electrical Engineer registered in the state where the project is being constructed. The engineer will be selected by the DG facility Owner and all engineering services will be performed at the Owner's expense. The DG facility Owner will also reimburse CUMING COUNTY PPD for the direct, actual expenses incurred by CUMING COUNTY PPD as a result of testing. An example of such expenses would be reimbursement for a CUMING COUNTY PPD crew or technician to 'stand by' during testing to be available in the event problems arise.

The DG facility Owner must keep all test results on file for review by CUMING COUNTY PPD. These tests may be required to be submitted as part of the 'Agreement for Closed Transition Operation of Distributed Generation'/'Application For CUMING COUNTY PPD Approval To Construct Distributed Generation (DG) Interconnection' renewal process, so files should be maintained for a minimum of the period between renewals. Refer to 'The Approval Process for DG Installations' renewal requirements.

CUMING COUNTY PPD Access to DG Facility Equipment

By submitting a completed 'Application for CUMING COUNTY PPD Approval to Construct DG Interconnection' (and as part of the terms of the

‘CUMING COUNTY PPD Agreement for Closed Transition Operation of Distributed Generation’) the DG facility Owner agrees to allow CUMING COUNTY PPD access to the DG facility under both normal and emergency conditions for the purpose of inspection and witness testing of the interconnection equipment.

Under normal conditions, CUMING COUNTY PPD intends to provide advance notice of all site visits and will coordinate such visits with the facility Owner or the Owner’s representative. Emergency conditions may require CUMING COUNTY PPD access the DG facility without advance notice.

Utility Service Termination Clause

By submitting a completed ‘Application for CUMING COUNTY PPD Approval to Construct DG Interconnection,’ and as part of the terms of the ‘CUMING COUNTY PPD Agreement for Closed Transition Operation of Distributed Generation’, the DG facility Owner agrees to the following:

CUMING COUNTY PPD has the right to require the DG Owner to immediately disconnect the generation facility without advance notice or liability if:

- There are any changes or alterations to the DG facility equipment unapproved by CUMING COUNTY PPD.
- In CUMING COUNTY PPD’s sole judgment, the facility has not incorporated necessary features for automatically counteracting the effect of anticipated possible sources of failure (fail-safe design).
- It causes any electrical problem(s) with other CUMING COUNTY PPD customers.
- May pose a risk to CUMING COUNTY PPD employees, customers or the general public.

The failure of the DG Owner to comply with any of the covenants or obligations contained herein gives CUMING COUNTY PPD the right to terminate its agreement with the DG Owner and to recover from the DG Owner the cost and expenses incurred by CUMING COUNTY PPD. The agreement is subject to all of the CUMING COUNTY PPD service regulations, rate schedules, and written policies regarding interconnection (except as modified by the agreement) and is subject to such changes or modifications as CUMING COUNTY PPD’s Management or Board of Directors may from time to time make in the service regulations, rate schedules, and interconnection policies.

The above clause is applicable to all distributed generation operating in parallel with CUMING COUNTY PPD system, including generation

discovered to exist on the CUMING COUNTY PPD system without the DG Owner having initiated or successfully completed the CUMING COUNTY PPD approval process for DG installations.

Nontransferable Agreements for Change of Ownership or Modified Facilities

Executed 'Application for CUMING COUNTY PPD Approval to Construct DG Interconnection' and 'CUMING COUNTY PPD Agreement for Closed Transition Operation of Distributed Generation' documents are not transferable to parties, DG facilities, or DG equipment other than those identified in the documents.

If the DG facility undergoes a change of Ownership, or the facility is modified, any existing agreements between the previous facility Owner and CUMING COUNTY PPD are considered null and void. The new DG facility Owner, or the Owner of a modified DG facility, does not have CUMING COUNTY PPD's permission for closed transition operation and will be subject to the terms of the 'Utility Service Termination Clause'. Such circumstances will require the execution of new forms of the above documents. Refer to 'The Approval Process for DG Installations' renewal requirements for additional information.

Interconnection Expenses

CUMING COUNTY PPD's maintenance and operation procedures are based on a single source serving the electric distribution system. Interconnection of additional generation or other modifications to the electric system will necessitate modification to these procedures. Often, the introduction of DG to the utility system requires capital expenditures for additional utility equipment. The modified procedures and additional utility equipment increase utility costs without providing benefits to other utility customers. In such cases, the expenses for additional CUMING COUNTY PPD procedures, equipment, maintenance, labor, and other related costs that are over and above the expenses for a non-generating customer must be paid to CUMING COUNTY PPD by the Owner of the DG facility.

These reimbursable costs are separate from DG Owner obligations to purchase, install, and maintain CUMING COUNTY PPD required interconnection equipment installed at the DG facility, as well as the cost of professional engineering services and maintenance testing to satisfy CUMING COUNTY PPD requirements.

The following expense categories are examples of items reimbursable to CUMING COUNTY PPD:

- Meter installation, tests, maintenance, parts, and related labor.
- Meter reading and scheduling, billing.
- Telemetry installation, tests, maintenance, parts, and related labor.
- Operating expenses, including communication circuits.
- Study, analysis, and related expenses.
- CUMING COUNTY PPD assistance in securing regional regulatory authority acceptance of the DG facility.
- Modifications to the CUMING COUNTY PPD system including related material and labor.
- Protective device (CUMING COUNTY PPD owned) installation/equipment cost and related labor.
- CUMING COUNTY PPD costs for DG facility design review, equipment inspections, and witness testing.
- Programming costs to incorporate generation data into CUMING COUNTY PPD's energy management system.

Changes to the CUMING COUNTY PPD system or the addition of other DG facilities in the vicinity may require modifications to the existing DG facility interconnection. If such changes are required, the existing DG facility will be subject to future charges for these modifications.

Also, a DG installation results in increased utility maintenance costs in the event of an extended outage on the utility circuit serving the DG facility to safeguard CUMING COUNTY PPD repair crews. CUMING COUNTY PPD will isolate the DG facility from the CUMING COUNTY PPD system by opening the interconnection disconnect(s) before restoring service to the disabled circuit. CUMING COUNTY PPD will return to the DG facility and close the interconnection disconnect(s) after the utility circuit is restored. These additional steps are only required for facilities with interconnected generation, but potentially delay restoration of service to all customers of the utility circuit.

The DG facility Owner is also responsible for any ongoing monthly charges (such as telephone bills associated with DG facility-to-CUMING COUNTY PPD voice or data communications) incidental to operation of the DG facility.

Contact Information

For Class I 'Type A', some Class I 'Type B', and smaller Class II installations, CUMING COUNTY PPD requires daytime and nighttime phone numbers for emergency contact purposes. Minimal additional generation Owner contact information is required. The contact person(s) should contact the CUMING COUNTY PPD Call Center at Norfolk whenever the CUMING COUNTY PPD electric system has a service interruption affecting their

generation equipment.

For larger Class II and Class III installations, CUMING COUNTY PPD requires a 24 hour/day, 365 day/year phone number for after hours and emergency contact purposes. The designated DG facility contact person(s) should have responsibility for and authority over operation of the generation and be able to provide information regarding facility events, equipment status, and relay target and alarm information upon CUMING COUNTY PPD's request. Also, the contact person(s) should notify CUMING COUNTY PPD whenever:

- Problems with generation equipment are detected that could result in misoperation of generation protection or other generation equipment.
- The generation has tripped off-line during parallel operation with the CUMING COUNTY PPD system.
- Generation equipment problems are believed to have resulted in an outage to a portion of the CUMING COUNTY PPD system.
- The DG facility intends to initiate abnormal switching to parallel the generation with the CUMING COUNTY PPD system.

Under certain circumstances, CUMING COUNTY PPD may determine additional contacts are required.

CLASSIFICATION OF THE DG INTERCONNECTION

CUMING COUNTY PPD categorizes interconnected (parallel) generation into three general classifications. These are Class I, II, and III. The major factors to be considered in the determination of the interconnection class include the point of utility interconnection, the generator ratings, the generation type, and the number of generators interconnected on the electrical service. Classification of the facility is determined by CUMING COUNTY PPD, based upon DG facility application information provided by the facility Owner.

Class I interconnections includes induction generators, line commutated power converters, and any other generating equipment that must be energized by the utility system to operate (excluding microturbine type generation). The VAR requirements of any induction generator interconnected to the electric system must be supplied locally by the DG facility. CUMING COUNTY PPD may, at its option, charge the DG facility for VAR impacts on the electric system.

The DG facility Owner must purchase, install, and maintain the required protective equipment for Class I interconnections where the protective equipment integral to the generation unit does not meet CUMING COUNTY

PPD requirements (see 'Protective Equipment' in this standard). The equipment requirements are dependent upon the 'type' of Class I interconnection. CUMING COUNTY PPD has two 'types' of Class I interconnection. The corresponding 'type' equipment requirements are as follows:

Class I 'Type A' Interconnections

This classification includes induction generators or generators with line commutated power converters rated 50 kW or below, single-phase or three-phase.

CUMING COUNTY PPD requires a separate interconnection disconnect and may require an interconnection breaker for devices classified as Class IA. CUMING COUNTY PPD will determine requirements for protective functions/relaying on a site-specific or equipment-specific basis.

NOTE: Should CUMING COUNTY PPD operate (open) the interconnection disconnect during a circuit outage, the opening of this disconnect should not affect the generator, as the utility source is required for generator operation.

Class I 'Type B' Interconnections

Consist of all other induction generators or generators with line commutated power converters rated greater than 50 kW, except those determined to require a Class II interconnection, and any other generating equipment that must be energized by the utility system to operate (excluding microturbine type generation). The DG Owner must furnish VARS equal to a minimum of 93% of the estimated reactive requirement of the generator installation.

CUMING COUNTY PPD will determine requirements for protective functions/relaying on a site-specific basis. An interconnection disconnect and an interconnection breaker is required.

Class II

Class II interconnections include generation equipment that operates independent of the utility, with rated capacity at or below 5 MW, and is interconnected to the utility at or below 15,000 volts.

Interconnections with synchronous generators or generators with self-commutating power converters are typically defined as Class II interconnections. Class II interconnections also typically apply to the interconnection of direct energy converters, most inverters, induction

generators with an adequate local VAR supply, and all microturbines (whether capable of operation independent of the utility or not).

The DG facility Owner must purchase, install, and maintain the required protective equipment (see ‘Protective Equipment’ in this standard) for all Class II interconnections. This equipment includes:

- A visible interconnection disconnect at each interconnection point.
- An interconnection breaker for each interconnection point.
- Protective functions/relaying in accordance with CUMING COUNTY PPD requirements.

CUMING COUNTY PPD may waive the interconnection breaker and protective relaying requirements for ‘momentary’ closed transition interconnections—refer to the ‘Duration of Parallel Operation’ section of this standard to determine if the load transfer equipment meets the ‘momentary’ classification.

Class III

Class III interconnections are for any interconnection in excess of 15,000 volts or for generation with a capacity in excess of 5 MW. CUMING COUNTY PPD will evaluate and specify the requirements for Class III interconnections on a site-specific basis. Class III interconnections may require, as a minimum, all requirements for a Class II interconnection. Class III facilities will often require an interconnection directly into the CUMING COUNTY PPD transmission system; see the CUMING COUNTY PPD document ‘Facilities Connection Requirements’ for additional requirements.

Interconnection Point

The interconnection point of CUMING COUNTY PPD to any DG facility is the point at which the CUMING COUNTY PPD system connects to devices, conductors, or equipment of the DG facility, as determined by CUMING COUNTY PPD. This point will normally be the ‘point of common coupling’ as defined in ‘IEEE Recommended Practices and Requirements for Harmonic Control in Electric Power Systems,’ IEEE Standard 519. The service entrance voltage is typically defined by the voltage at this point.

NOTE: DG facilities may not be able to meet CUMING COUNTY PPD DG requirements if the generation is interconnected at points in the DG facility system other than the service entrance. The DG facility Owner must verify the interconnection point with CUMING COUNTY PPD during the design stage.

Duration of Parallel Operation

The amount of time electric generation will operate in parallel (or ‘closed transition’) with the utility system will help determine the CUMING COUNTY PPD requirements for the DG facility. For the purpose of this standard, closed transition operation is either momentary or sustained. Momentary closed transition—used only for synchronized closed transition transfer of DG facility load from one source to another source—Sustained Closed Transition interconnects the two power systems to remain interconnected indefinitely, as long as synchronous operation is maintained.

TYPE OF CLOSED TRANSITION OPERATION	DURATION OF PARALLEL OPERATION	CUMING COUNTY PPD REQUIREMENTS FOR THE DG FACILITY
Momentary*	< 100 milliseconds	Synchronism check on transfers interconnection disconnect.
Sustained	> 100 milliseconds	All CUMING COUNTY PPD DG Standard requirements and additional requirements, as determined by *.

*Determination as to whether the DG equipment to be installed is the ‘momentary’ type above or not will be made by CUMING COUNTY PPD. A DG facility design proposal using a ‘closed transition transfer switch’ may be approved as ‘momentary.’ DG transfer equipment approved as ‘momentary’ must be designed, manufactured, and listed for use as ‘momentary’ transfer equipment, and is not designed for ‘sustained’ parallel operation. DG transfer equipment which meets the ‘momentary’ requirements above, but which relies on programmable electronic control means, and is capable of being re-programmed or otherwise altered to be capable of ‘sustained’ parallel operation, will be considered ‘sustained’ type. Note ‘momentary’ type of operation is still closed transition operation, and as such is not approved for applications involving network service (see ‘System Issues, Network Service’ in this standard). Automated switchgear capable of closed transition operations via programming or logic changes must meet the protective requirements and stipulations for sustained interconnections.

The ‘momentary’ interconnection, or closed transition transfer, can result in a large load suddenly being applied to the DG facility generation. This ‘step-loading’ can result in frequency and voltage disturbances that may be unacceptable to the DG facility load—the generator should be properly sized and selected to help prevent such power quality problems

Power Transfer

- Determination of kW Levels

All parallel operation power levels are measured on a per service/ per CUMING COUNTY PPD circuit basis, with adjustment for power factor.

Parallel operation power levels are calculated based on the maximum generation scenario: all available DG facility generation (including possible future generation) operating in parallel with the CUMING COUNTY PPD system.

Should a facility increase generation capacity or begin to export power in the future, a new ‘Agreement for Closed Transition Operation’ must be reached with CUMING COUNTY PPD—see ‘The Approval Process for DG Installations’ or ‘Renewals for Modified DG Equipment or Facilities’ sections.

Once power levels are determined and approved by CUMING COUNTY PPD for a DG facility, the facility will be restricted from operation outside the established power transfer boundaries.

Import-Only, Import/Export or Export-Only

Power transfers between a DG facility and a utility can be import, export, or a combination of these types. ‘Import’ is the typical power transfer from utility to a customer (a customer ‘imports’ power from the utility). ‘Export’ is power transfer from a DG facility to utility (the facility ‘exports’ to the utility). The majority of the utility/customer interconnections are import only, where there is no on-site generation or only open-transition load transfer to a generator. ‘Import/export’ arrangements are typical of parallel-capable generation facilities with on-site generation that may exceed the load requirements of that facility.

Examples of import/export arrangements include wind or solar power generation for residences. This type of arrangement will import power during heavy load periods when the on-site generation is unable to supply all the power requirements. During lightly loaded or no-load periods, portion of the on-site generation not used by the facility will be exported to the utility.

The DG Owner and CUMING COUNTY PPD must come to an understanding on the issue of whether the DG facility is to be used for import-only, import/export, or export-only power transfers with CUMING COUNTY PPD. The type of power exchange intended to occur between the DG facility and

CUMING COUNTY PPD will determine the protection and metering requirements for the facility.

THE DETAILED APPROVAL PROCESS FOR DG INSTALLATIONS

This section clarifies the process for connecting Class I, Class II, and/or Class III generators to the CUMING COUNTY PPD electric system.

Description of CUMING COUNTY PPD Forms

CUMING COUNTY PPD uses several forms to facilitate the application process for Distributed Generation Interconnection between an Owner and the Utility. The various forms are listed below with a short description. A copy of each is included in a later section of this standard.

- Application for CUMING COUNTY PPD Approval to Construct Distributed Generation (DG) Interconnection

This is the form to be used by an Owner to notify CUMING COUNTY PPD of the desire to install generation that will operate in closed transition with the electric system. The Owner uses this form to transmit information about the intended installation.

Upon written CUMING COUNTY PPD approval of the application, CUMING COUNTY PPD and Owner will be deemed to have entered into a temporary agreement relating to the DG interconnection, which will remain in effect until revoked by CUMING COUNTY PPD or until construction of the new interconnection is complete and the facilities are placed in service under the terms of the CUMING COUNTY PPD Agreement for Closed Transition Operation of Distributed Generation (see description below).

- CUMING COUNTY PPD Agreement for Closed Transition Operation of Distributed Generation

This agreement outlines the specifics of the physical interconnection between the facilities of CUMING COUNTY PPD and the DG Operator and any financial and facility requirements of each of the parties.

This is a long-term contractual arrangement required for the duration of the interconnection's existence.

Application Process for New Installations

CUMING COUNTY PPD utilizes a two-step approval process for any DG that will operate in parallel with the CUMING COUNTY PPD electric system. The DG Owner must obtain two authorizations from CUMING COUNTY PPD prior to beginning operation of the generation equipment:

- CUMING COUNTY PPD Approval to Construct DG Interconnection
- An Approved CUMING COUNTY PPD Agreement for Closed Transition Operation of Distributed Generation

For the DG Owner, or their representative, the following steps are involved in the DG approval process for new installations (for ‘accredited’ generation facilities additional steps are required for such facilities and are not addressed below):

1. Contact your CUMING COUNTY PPD Account Executive

Discuss with your representative the proposed generation installation and application process. Obtain current copies of the CUMING COUNTY PPD DG Standard, applicable rate schedules, and the ‘CUMING COUNTY PPD Agreement for Closed Transition Operation of Distributed Generation’ and review the documents. Become familiar with all requirements including: submittal requirements, protective equipment (including relay) requirements, metering and/or telemetry requirements (typical of Class II and III).

2. Submit ‘Application for CUMING COUNTY PPD Approval to Construct DG Interconnection’

Assemble all DG equipment information, installation drawings, and other information. Professional Electrical Engineer certification is required on submittals. The engineer must have a valid license for the state where the project is being constructed. Complete and sign an ‘Application for CUMING COUNTY PPD Approval to Construct DG Interconnection’ and submit the application with all material assembled.

3. CUMING COUNTY PPD Classification of Facility and Determination of Interconnection Study Requirements

Classification of the facility will be determined by CUMING COUNTY PPD, based upon DG facility application information provided by the facility Owner and determine if any additional materials are required to complete its review.

CUMING COUNTY PPD will provide a determination of Interconnection Study requirements. Typically all ‘accredited’ generation applications and

Class III interconnections (as well as many Class I or Class II applications) will require the applicant to enter into an Interconnection Study Agreement. Interconnection Study Agreements will address issues of reimbursement of CUMING COUNTY PPD by the DG applicant (see ‘Requirements for Closed Transition Operation, Interconnection Expenses’).

This study will determine the DG impact on the CUMING COUNTY PPD system. The Interconnection Study addresses items such as protective equipment requirements, equipment ownership, additional right-of-way acquisitions, preliminary cost estimates and schedules to construct/modify the CUMING COUNTY PPD system, and impacts introduced by the proposed generation on system operating conditions (voltage regulation, harmonics, ampacity, increase in short circuit currents, system stability, line losses).

4. CUMING COUNTY PPD Completes Interconnection Impact Studies

If further CUMING COUNTY PPD studies are required (typical of larger installations), the approval process is delayed at this point until the completion of the study phase. Study results will address issues of reimbursement of CUMING COUNTY PPD by the DG applicant (see ‘Requirements for Closed Transition Operation, Interconnection Expenses’).

Note such studies, if required, may require months for completion, and will require execution of study agreements between the applicant and CUMING COUNTY PPD.

If further CUMING COUNTY PPD studies are not required, protective equipment, metering, and other requirements may be finalized—the process continues below.

5. Obtain an Approved ‘Application for Distributed Generation Interconnection’ from CUMING COUNTY PPD

Upon written CUMING COUNTY PPD approval of the application, CUMING COUNTY PPD and Owner will be deemed to have entered into a temporary agreement relating to the DG interconnection, which will remain in effect until revoked by CUMING COUNTY PPD or until construction of the new interconnection is complete and the facilities are placed in service under the terms of the CUMING COUNTY PPD Agreement for Closed Transition Operation of Distributed Generation (see description below).

6. Complete Construction of the DG Facility

Release orders for and/or purchase of, any switchgear or DG equipment to be purchased for the installation. Complete construction of the DG facility. Complete any required preoperational tests.

7. CUMING COUNTY PPD Witness Test

Notify all parties and CUMING COUNTY PPD that facility is ready for parallel witness test and arrange date and time.

At the required CUMING COUNTY PPD ‘Witness Test,’ perform/demonstrate tests outlined in the ‘CUMING COUNTY PPD Agreement for Closed Transition Operation of Distributed Generation.’

Complete the performance/demonstration tests successfully with CUMING COUNTY PPD representatives present.

8. Submit Final Documentation

Submit copies of the final protective device settings and final one-line/power riser diagram to CUMING COUNTY PPD (PE stamp normally required).

9. Execute ‘CUMING COUNTY PPD Agreement for Closed Transition Operation of Distributed Generation’

Execute ‘CUMING COUNTY PPD Agreement for Closed Transition Operation of Distributed Generation’ and reimburse CUMING COUNTY PPD for any unpaid interconnection expenses.

DG Installation Renewals

Renewals are required for expired ‘Application For CUMING COUNTY PPD Approval To Construct Distributed Generation (DG) Interconnection’ certificates, for modified DG facilities, and for new DG facility Owners as follows.

- **Simple Renewal**

If no modifications have been made to the DG equipment or facility electric service entrance, and the facility has not had a change of ownership or control, contact CUMING COUNTY PPD, and:

- Obtain current copies of the CUMING COUNTY PPD DG

Standard, Applicable Rate Schedules, and the 'CUMING COUNTY PPD Agreement for Closed Transition Operation of Distributed Generation' and review the documents to become familiar with all requirements.

- Submit documentation (with PE seal) of required periodic tests; see 'Requirements for Closed Transition Operation, Periodic Testing' in this standard.
- Be prepared to perform a CUMING COUNTY PPD Witness Test as outlined in the 'CUMING COUNTY PPD Agreement for Closed Transition Operation of Distributed Generation.'
- Be aware CUMING COUNTY PPD may require the existing DG equipment or facility be modified to meet the requirements of the latest DG Standard.

Upon meeting all CUMING COUNTY PPD requirements, CUMING COUNTY PPD will forward a new 'Application For CUMING COUNTY PPD Approval To Construct Distributed Generation (DG) Interconnection'. When it is received, it must be permanently posted as required.

- Renewals for Modified DG Equipment, Facilities, or New DG Owners

If the facility electric service or DG equipment has been or will be modified, or if the facility will undergo a change of ownership or control, CUMING COUNTY PPD should be contacted at the earliest possible date. This will allow a joint review of the facility to determine what revisions, if any, will be required to allow the DG to continue operation.

If the facility electric service or DG equipment will be or has been modified, it will be necessary for CUMING COUNTY PPD to review all modifications for compliance with current CUMING COUNTY PPD requirements. For minor modifications, CUMING COUNTY PPD will evaluate the impact of the modifications against CUMING COUNTY PPD DG requirements. If the modifications involve expansion of the existing DG capacity or major modifications to the facility electric service or DG equipment, CUMING COUNTY PPD will evaluate the changes in a similar manner to the approach taken for 'New Installations' above.

If the facility or DG equipment has or will undergo a change of ownership or control, but has not and will not be modified, the new facility Owner must apply for an 'CUMING COUNTY PPD Agreement for Closed Transition Operation of Distributed Generation.' This will require the new Owner to complete the

following items:

- Obtain current copies of the CUMING COUNTY PPD DG Standard, applicable rate schedules, and the 'CUMING COUNTY PPD Agreement for Closed Transition Operation of Distributed Generation' and review the documents to become familiar with all requirements.
- Have CUMING COUNTY PPD verify the previous classification of the DG equipment as defined in the DG Standard (Class I, II, or III, import only or export, kW level) and any existing operating restrictions, by examination of previous approvals/records.
- Verify with CUMING COUNTY PPD the existing installation and classification, any submittal and periodic testing requirements and PE certification. Submit documentation (with PE seal) of required periodic tests. Periodic tests are discussed in the section 'Requirements for Closed Transition Operation, Periodic Testing' in this standard.
- Supply any additional materials or respond to any questions regarding the installation as requested by CUMING COUNTY PPD.
- Verify DG facility protection equipment matches facility and CUMING COUNTY PPD records, and such records are in the possession of the new Owner.
- Be aware CUMING COUNTY PPD may require a Witness Test as outlined in the 'CUMING COUNTY PPD Agreement for Closed Transition Operation of Distributed Generation'.
- Be aware CUMING COUNTY PPD may require the existing DG equipment or facility be modified to meet the requirements of the current DG Standard.

Upon meeting all CUMING COUNTY PPD requirements, CUMING COUNTY PPD will forward to the DG Owner a new 'CUMING COUNTY PPD Agreement for Closed Transition Operation of Distributed Generation'.

TECHNICAL REQUIREMENTS

Overview

- Adverse Effect

The utility-DG interconnection must not adversely affect the utility's other customers. Possible adverse effects to other utility customers include (but are not limited to):

- Reduction in quality of electric service.
- Higher cost of electricity.
- Expenditure of CUMING COUNTY PPD capital for interconnection without benefit to other customers.

- Interconnection Hazards

Proper operation of two independent power sources such as the utility source and a no utility generation source in closed transition results in a parallel operation of the two systems. The electrical attributes of both systems must be identical prior to and during the period of parallel operation. Any attempt to interconnect the two power systems while they do not share identical attributes will result in problems ranging from tripping of the circuit breaker at the interconnection point to severe equipment damage and hazardous conditions for personnel on both sides of the interconnection.

- Islanding

Automatic and manual switching arrangements on the CUMING COUNTY PPD transmission, subtransmission, and distribution system are based on the premise that, upon opening a line or section of the CUMING COUNTY PPD system, it becomes de-energized. Distributed generation equipment that remains energized and interconnected to the isolated portion of the system or reconnects before service restoration, creates a hazardous condition for utility employees and for this reason, CUMING COUNTY PPD does not allow DG facilities to operate as an island on the CUMING COUNTY PPD system. The DG facility must automatically isolate itself from the de-energized portion of the CUMING COUNTY PPD system in the event of a CUMING COUNTY PPD outage.

- Protective Equipment

CUMING COUNTY PPD requires the installation of protective equipment that must be designed and tested to protect the electrical systems and personnel of the DG facility, CUMING COUNTY PPD, and the general public under all operating and maintenance conditions. These requirements are also applicable to automated open transition switchgear capable of closed transition operations via programming or logic changes.

NOTE: All open transition switchgear (either automated or manual via a transfer switch) capable of closed transition operations must meet NEC requirements and must be installed by a qualified licensed

electrician.

In some cases, site-specific factors will determine the technical requirement unique to the proposed DG installation.

Power Quality Restrictions for Generation

- Operating Limits

The following restrictions are provided for information only, and do not necessarily represent CUMING COUNTY PPD requirements for a specific DG facility. CUMING COUNTY PPD will determine specific operating limits during the course of the CUMING COUNTY PPD facility approval process. In most cases, CUMING COUNTY PPD requirements will be consistent with the latest version of IEEE P1547 ‘Standard for Interconnecting Distributed Resources with Electric Power Systems,’ other applicable standards, and the following:

- Voltage

The voltage regulation of the DG must be adequate to ensure any out-of-bound condition will be corrected to within the control limit within 2 seconds. The voltage control limits for the DG are the ANSI C84.1 ‘A’ range limits (+/- 5%) for the service voltage (see Point of Common Coupling—PCC in glossary). The DG must automatically disconnect from the CUMING COUNTY PPD system after 2 seconds of operation outside of the voltage control limits.

- Voltage Flicker

The DG operation must not result in objectionable flicker on the utility system for other connected customers at the point of common coupling. Objectionable voltage flicker is defined as, causing equipment misoperation, or the flickering of lamps at levels irritating to humans. Reference IEEE Std. 519-1992, IEEE P1453, IEC/TR3 61000-3-7, IEC 61000-4-15, IEC 61400-21.

- Frequency Control

The frequency of the DG must not deviate more than +/- 0.5 Hertz from the 60 Hertz base (59.5 Hz minimum—60.5 Hz maximum). The DG must automatically disconnect from the CUMING COUNTY PPD system within 1 second if the frequency exceeds the 0.5 Hz limit.

- Power Factor

DG facilities must provide for their own reactive power needs. Non-exporting DG facilities must operate the combined generation and load within a range of +93% to -93% power factor. Power factor charges specified in the CUMING COUNTY PPD Rate Schedules will apply to power factors outside of this range.

All exporting DG facilities must operate at unity power factor unless otherwise specified by CUMING COUNTY PPD.

- Harmonics

The Total Demand Distortion (TDD) of the current of an exporting DG must not exceed 5%, measured at the point of common coupling. The harmonic spectrum must not exceed the IEEE 519 limits specified in table 10.3 for the 5% TDD category.

The TDD of the voltage of a DG must not exceed 5% at the point of common coupling.

The DG facility Owner is responsible for the installation and expense of any additional equipment needed to prevent an objectionable increase in the utility system voltage TDD due to operation of the DG.

- Export Power Requirements

The quality of the generated AC power depends on the construction of the generator or static power converter. Certain DG types may produce electrical waveforms that are not clean sinusoidal wave shapes. Low quality power is unacceptable for export to the utility.

Where DG facilities intend to export power utilizing rotary type AC generators, the generators must have a skewed rotor or winding pitch of approximately $2/3$ to ensure clean AC production and low third harmonic generation. Generators exporting power through an Owner's delta-wye transformer (delta on the generator side) may be allowed to use other winding pitches as the delta winding should trap triple-n harmonics.) (This situation is most common with larger Class II or Class III DG facilities.)

Protective Equipment

Closed transition operation of distributed generation (DG) on the CUMING COUNTY PPD system will normally require the installation of certain 'protective' equipment. This equipment is purchased, installed, and maintained by the DG facility Owner. This section does not describe the conditions under which protective equipment is required (refer to 'Classification of the DG Interconnection' for this information), but outlines the requirements for such equipment and the conditions of its use.

The typical installed location of an interconnect disconnect switch, interconnection breaker, CUMING COUNTY PPD revenue metering, and protective relaying is indicated in the 'Standard Interconnection Diagram' below. As each DG facility is approved on a case-by-case basis, actual installed equipment locations may vary.

Where 'grounding provisions' are indicated in the diagram, CUMING COUNTY PPD requires a means to be provided for temporary installation of CUMING COUNTY PPD grounding cables. The grounding cables are intended for protection of CUMING COUNTY PPD personnel during repair or maintenance operations, and consist of clamp and cable assemblies used to temporarily connect a conductor to ground. CUMING COUNTY PPD will review proposed protective equipment for these required features.

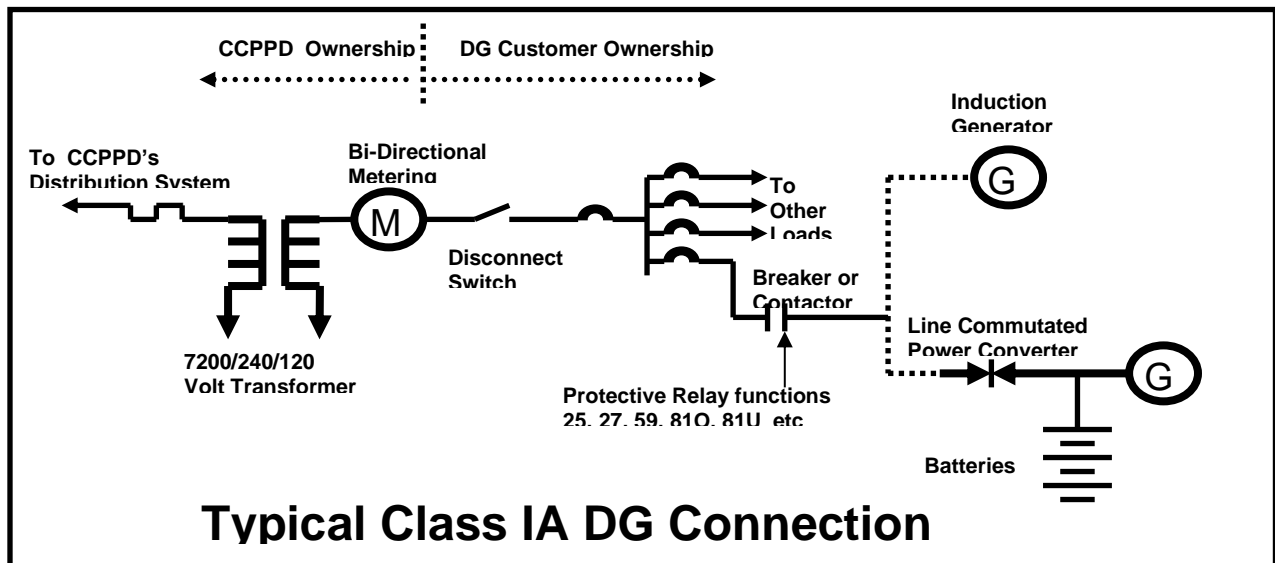

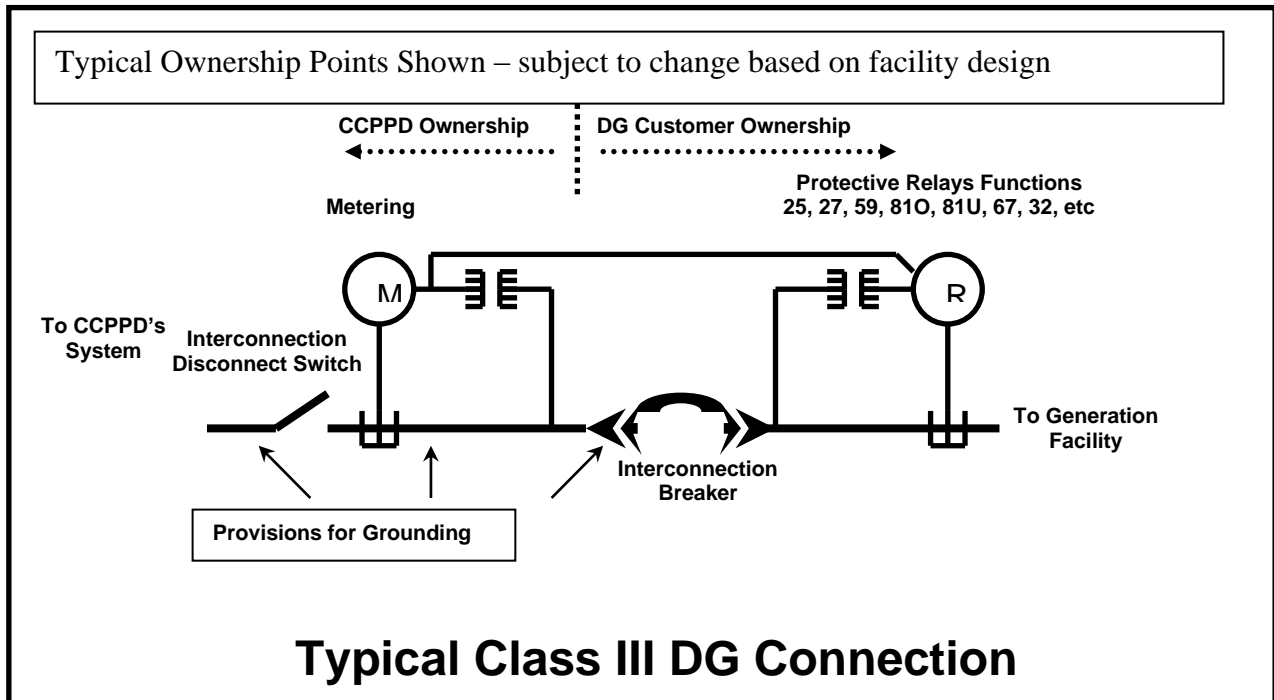

Interconnection protective equipment owned by the DG facility should be maintained and inspected by the DG facility Owner according to the equipment manufacturer's recommendations and/or industry standards. Procedures should be established for visual and operational inspections and for equipment maintenance and testing. Equipment maintained and inspected should include, but not be limited to:

- Circuit Breaker(s)
- Protective Relaying
- Control Batteries

CUMING COUNTY PPD maintains the right to review maintenance, calibration, and operation data of all protective equipment for the purpose of protecting the CUMING COUNTY PPD system and other CUMING COUNTY PPD customers. The DG facility Owner is responsible for providing the necessary test accessories (such as relay test plug, instruction manuals, wiring diagrams, etc.) required to test these protective devices.

- Interconnection Disconnect

Each interconnect disconnect switch must meet the following requirements:

- Be rated for the service voltage and phasing (i.e., single or three-phase).
- Be rated not less than the ampacity rating of the service entrance equipment.
- Be manually operable and simultaneously open all ungrounded conductors.
- The interrupting rating must be suitable for the available fault current from either the utility or DG source(s) (whichever is greater).
- The switch will be load break type with arc arrestors and provide a visible means of verifying the switch contacts are in the open position with the switch enclosure open. Switch designs requiring removal of plates, covers or partial disassembly of the switch to provide visual access to the contacts, are not acceptable to CUMING COUNTY PPD.
- The switch enclosure NEMA rating must be appropriate for the specific application and installed location.
- The switch must have provisions for padlocking the switch in the open and closed position and must accommodate a standard CUMING COUNTY PPD padlock, to be provided by CUMING COUNTY PPD.
- The switch must have provisions for grounding all phase conductors and neutrals (on both sides of contacts) to a proper grounding conductor/electrode within the switch enclosure. CUMING COUNTY PPD must be able to close and secure the disconnect door or cover with the ground jumpers in place.

NOTE: The switch is not required to be fused. Fused switches are not restricted, but removal of the fuses will not be required to meet the 'visible means of open switch position' described above.

Each interconnect disconnect switch must be installed as follows:

- The switch enclosure (if conductive) and switch grounding provisions will be grounded in accordance with the NEC and local codes.
- A grounding bar or other grounding point must be provided within the switch enclosure for termination of CUMING COUNTY PPD grounding cables. The grounding point must allow the CUMING COUNTY PPD grounding cables to be installed with the switch in the open position and the switch door closed and locked.
- The switch must be installed in a location readily accessible to CUMING COUNTY PPD personnel (i.e., be erected as a drive-up location). Locked fences or other permanent barriers must not

restrict CUMING COUNTY PPD access to the switch. Fences may be secured with a chain and series connected CUMING COUNTY PPD and Owner padlocks, so either CUMING COUNTY PPD or the Owner has access without the other present.

- The switch will normally be installed on the secondary side of the CUMING COUNTY PPD service transformer. This will be at or before the interconnection point, on the line side of the CUMING COUNTY PPD revenue metering equipment and the customer main disconnect. In this location, when open, it will electrically separate the DG facility electrical system from the CUMING COUNTY PPD system (excluding the neutral conductor).
- Where installed in the vicinity of similar disconnect switches, the switch must be clearly labeled as the Interconnection Disconnect Switch so as to be readily identifiable by CUMING COUNTY PPD personnel.

Each interconnect disconnect switch is subject to the following conditions:

- Must not serve a dual role as both the CUMING COUNTY PPD-required interconnect disconnect switch and the NEC-required service disconnecting means, as additional NEC service entrance overcurrent protection devices will not be allowed to bypass the interconnection disconnect switch.
- Is under the sole control of CUMING COUNTY PPD, unless CUMING COUNTY PPD should release the switch for DG Owner operation. The DG Owner must not remove any CUMING COUNTY PPD padlocks or CUMING COUNTY PPD safety tags. CUMING COUNTY PPD will be allowed unrestricted access to the switch and will operate the switch under conditions and at times deemed appropriate by CUMING COUNTY PPD. Examples of conditions under which CUMING COUNTY PPD may operate the switch include:
 - o CUMING COUNTY PPD performing maintenance work on the CUMING COUNTY PPD system.
 - o CUMING COUNTY PPD system emergency.
 - o Discovery of a condition involving the DG facility's equipment or operation which threatens the CUMING COUNTY PPD system.
 - o Failure of the DG facility to provide maintenance and testing reports when required.
 - o The DG facility's generating equipment interferes with other CUMING COUNTY PPD customers or with the operation of the CUMING COUNTY PPD system.
 - o The DG facility's generating equipment or protective devices

are discovered to have been modified without the approval of CUMING COUNTY PPD.

- Discovery of parallel operation of unapproved generating equipment.
 - Use of the switch is to provide positive separation of the DG source from the CUMING COUNTY PPD system to effect maintenance or repairs to the CUMING COUNTY PPD system. CUMING COUNTY PPD will normally attempt to notify the DG facility Owner or operator prior to operation of the switch, but CUMING COUNTY PPD reserves the right to operate the switch without Owner notification.
 - If CUMING COUNTY PPD should not open the Interconnection Disconnect Switch, such act will not serve to relieve the DG facility Owner of any liability for injury, death, or damage attributable to the negligence of the DG facility Owner.
 - Desire of the Owner to operate the switch for maintenance, testing, or construction purposes will require them to contact CUMING COUNTY PPD for temporary removal of the padlock. The Owner or the Owner's representative will operate the switch for these conditions. Upon completion of their activities, the Owner must notify CUMING COUNTY PPD to reinstall the padlock with the switch in either the open or closed position, as left by the Owner. For reoperation of the switch, the Owner must contact CUMING COUNTY PPD to repeat the process.
- Interconnection Breaker

Each interconnection breaker must meet the following requirements:

- Circuit breaker construction is normally required for the interconnection breaker.
- Be draw-out type with provisions for locking the cubicle with the breaker open and in the unracked position. Provisions must be made to open the voltage sensing circuits when the draw-out breaker is in the open position (i.e., fused cutouts).
- Be rated for the service voltage and phasing.
- Carry an ampacity rating not less than that required, in accordance with the National Electrical Code (NEC).
- Be designed to open all ungrounded conductors simultaneously.
- Be rated for the available fault current from either the utility or DG source(s) (whichever is greater).
- The breaker enclosure must be suitable for its installed environment.
- The breaker must have provisions for grounding all phase

conductors and neutrals to a proper grounding conductor/electrode, as indicated in the 'Standard Interconnection Diagram'. If a grounding rack is provided (for draw-out breakers) to meet this requirement, the rack should be stored and available at the breaker location.

- For three-phase service, the trip and close coils of the breaker must be direct current (DC) type.

Each interconnection breaker must be installed as follows:

- The breaker will normally be the first breaker on the customer side of the CUMING COUNTY PPD revenue meter.
- While the actual protective functions/relaying required for each DG facility must be determined, the protective functions/relaying required will normally monitor conditions at this breaker and operate this breaker in the event a trip is required.

Each interconnection breaker is subject to the following conditions:

- When a trip signal is received from CUMING COUNTY PPD to open the DG facility interconnection breaker, the signal is intended to supplement, but not replace, protective relaying installed at the DG facility. The failure of the CUMING COUNTY PPD signal to open the interconnection breaker will not serve to relieve the DG facility Owner of any liability for injury, death, or damage attributable to the negligence of the DG facility Owner.
- Where a draw-out interconnection breaker is installed, if required, a crane must be provided and available at all times at the breaker location for use with draw out breakers and/or test racks.
- If a draw-out type interconnection breaker is not provided, when CUMING COUNTY PPD must perform work requiring the breaker path to be visibly open and the breaker grounding provisions utilized (as indicated in the 'Standard Interconnection Diagram'), CUMING COUNTY PPD may require 1) all DG facility generation unit disconnects be visibly open and locked (by CUMING COUNTY PPD) in the open position, or, 2) the interconnection breaker be physically unbolted and removed from its installed location, and later reinstalled at the completion of CUMING COUNTY PPD work by a qualified electrician at the expense of the DG facility Owner.
- While the actual protective functions/relaying required for each DG facility must be determined, the breaker is required to have synchronization capability, to open for abnormal frequency conditions, and to open for any loss of utility voltage. These requirements help prevent the electric generation from backfeeding

and energizing the utility system in the event of a CUMING COUNTY PPD outage. The breaker can only be closed if the utility voltage is nominal and stable and the synchronism check relay permits.

Protective Functions\Relaying

DG facility electrical system designs often include two groups of protective relays. One group is assigned the task of protecting the utility system from the DG (these relays usually operate the interconnection or main service breaker). A second group is responsible for the protection of the DG facility generation equipment (these relays usually operate the main generator breaker(s)). Where relay information, settings, drawings, etc., are to be submitted to CUMING COUNTY PPD for review, only the information pertaining to this first group is required. The DG applicant submits the generator relay settings to CUMING COUNTY PPD for reference purposes only. The DG Owner or their representative should note careful setting coordination is required between these two relay groups. This coordination ensures proper operation of the customer side system. Some interconnections will not include a separate relay group for utility side protection. The generation protection group will also provide utility-side protection (by tripping the main generator breaker or through shutdown of the inverter output of a direct energy converter).

CUMING COUNTY PPD protective relay requirements tend to become more stringent in proportion to the potential impact of a DG facility on the CUMING COUNTY PPD system (and other CUMING COUNTY PPD customers). This standard should be considered a guide in regard to protective relaying. In most cases, CUMING COUNTY PPD requirements will be consistent with the latest version of IEEE P1547 ‘Standard for Interconnecting Distributed Resources with Electric Power Systems,’ and other applicable standards. CUMING COUNTY PPD will determine specific protective relay requirements during the DG facility design review stage. Upon review of the DG applicant’s design for the proposed parallel installation, CUMING COUNTY PPD may require changes to the protection scheme. CUMING COUNTY PPD may refuse the use of certain protection methods, equipment, equipment grades, or manufacturer’s products.

CUMING COUNTY PPD retains the right to approve or reject the type of protective relays/devices used and the relay settings. The relays may be microprocessor based, solid-state, or electromechanical construction. While not required, CUMING COUNTY PPD highly recommends consideration is given to microprocessor-based relaying in place of electromechanical or solid state relaying, especially microprocessor based relays designed specifically for protection of the utility-DG interconnection point. In many cases, multiple protective device functions can be combined in a smaller, less expensive

package, resulting in savings for the DG Owner.

CUMING COUNTY PPD requires the protective functions/relaying operate as intended under all conditions, including for a loss of the normal power source serving the protection scheme. The DG facility protection system must account for this possibility in its design, and utilize a DG power supply with battery backup or other means of assuring proper operation for all conditions.

Many solid state or microprocessor-based relays are capable of external indication of a relay internal failure or alarm condition. CUMING COUNTY PPD may require such relays to trip the interconnection (or generation) breaker immediately upon relay alarm or failure indication, or act to prevent parallel operation of generation with CUMING COUNTY PPD until such time as the alarm or failure condition is corrected.

The relays must monitor all ungrounded conductors. For example, protection of a three-phase system using single-phase relaying is unacceptable.

The DG facility Owner is responsible for synchronization of DG facility generation to the CUMING COUNTY PPD System. The DG facility must be in synchronism with the utility system just prior to closing the appropriate DG facility sync-protected circuit breaker (often the interconnection breaker) and during the entire period of parallel operation. Protection function 25 (synchronism check) is for all classes.

CUMING COUNTY PPD does not allow islanding (see glossary) of DG facilities on the CUMING COUNTY PPD system. The DG facility must isolate itself from the CUMING COUNTY PPD system in the event of an CUMING COUNTY PPD outage. This fact must be taken into consideration in the setting of DG facility protective relays, so the interconnection breaker opens as soon as possible after sensing the utility source has been lost.

Protective relays can generally be categorized into two major groups: industrial grade and utility grade. Industrial grade may be considered PLC's or protection functions integral to the control system of small generation equipment. CUMING COUNTY PPD requires DG facilities with net generation above 50 kW use utility grade relays (meeting IEEE/ANSI C37.90 design standards—see glossary). Utility type test switches must be installed in conjunction with utility grade relays.

Class I interconnections, inverter type generation equipment rated up to 10 kW, single-phase and manufactured and listed for use in parallel with utility electrical service must comply with the requirements of ANSI/IEEE 929. Requirements include minimum 25, 27, 59, 81O, and 81U protection functions (see glossary).

Minimum protection function requirements, regardless of class or size, include minimum 25, 27, 59, 81O, and 81U protection functions (see glossary).

Minimum protection function requirements are listed in the table below:

CLASSES	MINIMUM PROTECTIVE FUNCTIONS
Class IA Induction Generator/Line Commutated Inverter 50 kW or Less	25, 27, 59, 81O, 81U
Class IB Induction Generator/Line Commutated Inverter greater than 50 kW	25, 27, 59, 81O, 81U
Class II Synchronous Generator/ Forced Commutated Inverter Less than 5,000 kW	25, 27, 59, 81O, 81U, 67, 67N
Class III Synchronous Generator/ Forced Commutated Inverter	25, 27, 59, 81O, 81U, 67, 67N, 32,

(See glossary for device designations).

Other functions, which CUMING COUNTY PPD may require, include (but are not limited to): 21, 32 (three-phase), 46, 67 (all phases), 67G/67N, and 68. CUMING COUNTY PPD may also require the following items:

- Spare dry contacts in the DG generation control system for tripping and/or monitoring of the DG facility
- Communications channel(s) with communications equipment
- A remote-trip system (CUMING COUNTY PPD sends a signal to trip the DG facility interconnection breaker)
- Duplicate/redundant/backup relays
- Or other specialized equipment

‘Vector Jump/Step Frequency,’ 47, 50, 50G, 50N, 51, 51G, 51N functions are not usually required by CUMING COUNTY PPD, but if installed, settings information and curves are required to be included in submittals for review.

CUMING COUNTY PPD SYSTEM REQUIREMENTS

Metering and Telemetry Equipment Metering

CUMING COUNTY PPD uses two styles of metering equipment for

traditional utility revenue metering: self-contained meters and instrument transformer meters. Self-contained meters are a series-connected measurement device and, therefore, are an integral part of the power circuit—removal of the meter interrupts the power flow. Self-contained meters usually are not rated over 320 amps. For capacities beyond 320 amps, and/or nominal voltages 480 volts and higher, instrument transformer meters are typically installed. When instrument transformer meters are used, a current transformer and a potential transformer send an output signal to the peripheral meter—the meter is not an integral part of the power circuit.

The pricing difference between import and export transactions requires special metering to measure energy flows. Import/export interconnections require metering equipment that is capable of separately recording the import and export transactions.

The facility Owner is responsible for the installation of the appropriate meter socket for self-contained import/export meters. CUMING COUNTY PPD will provide appropriate metering equipment enclosures for instrument transformer import/export meters. CUMING COUNTY PPD will determine and advise the Owner of such meter requirements for facilities on a case-by-case basis.

For installations that fall under Policy Bulletin 4000 “Net Metering” CUMING COUNTY PPD shall provide at no additional cost to any customer-generator with a qualified facility a metering system that is capable of measuring the flow of electricity in both directions and may be accomplished through use of a single, bidirectional electric revenue meter that has only a single register for billing purposes, a smart metering system, or another meter configuration that can easily be read by the customer-generator.

CUMING COUNTY PPD may, at its own expense install additional monitoring equipment to separately monitor the flow of electricity in each direction as may be necessary to accomplish the reporting requirements per LB 436.

Installations that fall outside Policy Bulletin 4000 “Net Metering” will require that the DG Operator pay all costs for the metering system furnished by CUMING COUNTY PPD.

Larger DG installations may require additional metering equipment, including recorders, additional metering accuracy CT’s (possibly installed at the output of DG generation equipment), and telephone line(s) for CUMING COUNTY PPD dial-up access to CUMING COUNTY PPD equipment. Such requirements will be communicated to the Owner during the design stages of the project. A GPR (Ground Potential Rise) study may be required for installing a telephone line in a DG facility.

Telemetry

Telemetry is the real-time, instantaneous monitoring of conditions at the DG facility by CUMING COUNTY PPD. Telemetry is accomplished by interfacing DG facility equipment or systems with the CUMING COUNTY PPD Energy Management System (EMS).

CUMING COUNTY PPD will determine any telemetry requirements for DG installations. In most cases, telemetry is only required for DG facilities capable of exporting to the CUMING COUNTY PPD system, or for any accredited facility intending to sell power over the CUMING COUNTY PPD system. CUMING COUNTY PPD will determine whether telemetry is required for a DG facility in the DG design review stage.

When telemetry is required, the DG facility Owner and CUMING COUNTY PPD must coordinate the details of the required communications medium and equipment for telemetry. The Owner is responsible (directly or through reimbursement to CUMING COUNTY PPD) to provide the communications path to CUMING COUNTY PPD's satisfaction. Some communications medium options (such as lease line telephone) involve ongoing monthly charges. Such charges are the responsibility of the DG facility Owner, see 'Requirements for Closed Transition Operation, Interconnection Expenses' in this standard.

Other technical and contractual issues may arise during the design and implementation of a telemetry system and will be addressed by all parties on a case-by-case basis.

Service Transformers

All new and most existing CUMING COUNTY PPD three-phase service transformers, are wye-wye type (installed grounded wye-grounded wye). CUMING COUNTY PPD will typically own and install wye-wye transformers for service to three-phase Class I DG interconnections (refer to 'Classification of the DG Interconnection' in this standard). CUMING COUNTY PPD prefers wye-wye service transformers for DG facilities for technical reasons, and will often want to replace or reconfigure transformers that are not wye-wye configuration.

Existing delta-delta or ungrounded wye-delta service transformers installed at DG facilities will require reconfiguration of the transformers to wye-wye or the installation of utility side voltage unbalance protection equipment. In some cases, upgrading of CUMING COUNTY PPD transformer insulation levels and lightning arrester ratings to a higher voltage may be required. The DG

facility Owner is responsible for the installation and material costs of such equipment (see ‘Requirements for Closed Transition Operation,’ ‘Interconnection Expenses’ in this standard).

Class III interconnections typically use a wye-delta step-up transformer (DG facility owned, with delta on the generator side) for connection to the CUMING COUNTY PPD electric system.

To provide isolation and minimize possible adverse effects on other CUMING COUNTY PPD customers from DG facility generation, all DG facilities with three-phase electric service must be connected to CUMING COUNTY PPD through a dedicated service transformer. Such DG facilities may not share the secondary or load side of the CUMING COUNTY PPD service transformer with other CUMING COUNTY PPD customers.

DG facilities with single-phase electric service where the DG is utilizing nonsynchronous inverter technology requiring connection with the utility to maintain synchronous operation will not be required to have a dedicated service transformer. All other single-phase DG installations will require a dedicated service transformer.

CUMING COUNTY PPD will determine the transformer connection and grounding configuration required. While in the facility design stage, the DG facility Owner should always verify with CUMING COUNTY PPD the details of the electric service (voltage, phase, ampere rating, etc.) and the service transformer winding configuration.

Automatic Reclosing

It is CUMING COUNTY PPD practice to apply automatic reclosing of circuit protective devices in the substation (see glossary) to transmission and distribution circuits.

Existing automatic reclosing schemes for CUMING COUNTY PPD distribution circuits assume the circuit is dead (de-energized) prior to reclosing. The protective relays and other controls do not employ voltage check, synchronization check, or phase checking functions. The introduction of a DG facility may require the addition of equipment and modification of the protection scheme to the CUMING COUNTY PPD circuit serving the DG facility. The cost of this additional equipment and its installation are the responsibility of the Owner of the new DG facility (see ‘Interconnection Expenses’ in this standard). The added functions are intended to prevent reclosing of the CUMING COUNTY PPD protective devices in the event a DG facility is energizing the CUMING COUNTY PPD circuit by operating in an ‘islanding’ condition (see glossary).

Those applying for DG facility approval will be informed when this equipment is required and the DG Owner is responsible for those costs.

The DG facility must not energize a de-energized CUMING COUNTY PPD circuit. It is the responsibility of the DG Owner to ensure the DG equipment does not allow operation in an 'islanding' condition. Should the utility source be lost or a fault occur on the utility side of the interconnection, the local DG generation must disconnect itself from the CUMING COUNTY PPD system by tripping the interconnection breaker prior to automatic reclosing of the CUMING COUNTY PPD protective devices. CUMING COUNTY PPD assumes no responsibility for damage to DG equipment due to out-of-phase reclosing.

The amount of reclosing time delay on CUMING COUNTY PPD circuits varies depending on many factors. While in the facility design stage, the DG facility Owner should always verify (with CUMING COUNTY PPD) reclosing details for each DG facility service.

ATO Service

ATO (Automatic Throw Over) service is common to hospitals and some other types of customer facilities requiring a backup CUMING COUNTY PPD circuit in the event of a CUMING COUNTY PPD circuit outage.

Many technical issues arise when it is proposed Distributed Generation (DG) operate in closed transition with CUMING COUNTY PPD while served from an ATO service.

ATO service is a complicating factor to the CUMING COUNTY PPD DG approval process. Should modifications to the CUMING COUNTY PPD system or equipment be required, the DG facility Owner is responsible for the labor and material costs of such modifications (see 'Requirements for Closed Transition Operation', 'Interconnection Expenses' in this standard).

Single-Phase Devices

CUMING COUNTY PPD may require replacement of single-phase over current devices (line fuses, single-phase automatic circuit reclosers, single-phase line switches) on the CUMING COUNTY PPD circuit between the CUMING COUNTY PPD substation and the DG facility service entrance. These components would be replaced with three-phase devices to minimize the possibility of single-phasing a three-phase DG facility. If required, the cost of the removal of single-phase devices and the addition of three-phase devices (equipment and installation) are the responsibility of the Owner of the new DG facility (see 'Interconnection Expenses' in this standard). In some cases,

these single-phase devices will be left in place.

Regardless of whether any single-phase devices are replaced with three-phase devices, the DG Owner is responsible for protecting DG equipment from the effects of excessive negative sequence currents, system imbalance effects, or loss of utility phase/utility single-phase conditions. CUMING COUNTY PPD assumes no responsibility for damage to DG equipment due to these effects.

PRE-PARALLEL REQUIREMENTS

CUMING COUNTY PPD Agreement for Closed Transition Operation of Distributed Generation

A fully executed 'CUMING COUNTY PPD Agreement for Closed Transition Operation of Distributed Generation' must be completed prior to actual parallel operations of the DG facility generation with CUMING COUNTY PPD's system. Refer to the terms of the 'CUMING COUNTY PPD Agreement for Closed Transition Operation of Distributed Generation' for requirements to be met prior to the actual parallel operation of DG facility generation with the CUMING COUNTY PPD system. Copies of the agreement are available for review. Additional requirements not outlined in that document are as follows:

- Engineering Drawings

A copy of the final power riser diagram or one-line diagram indicating the DG installation on the DG facility electrical system must be in CUMING COUNTY PPD possession. The document must note all bus voltages, conductor properties, generating equipment, interconnection point(s), and interconnection disconnecting device(s).

NOTE: CUMING COUNTY PPD will require the final version of this document bear the stamp of a professional electrical engineer registered in the state where the project is being constructed.

- Final Documentation

The following items are also required prior to execution of the 'CUMING COUNTY PPD Agreement for Closed Transition Operation of Distributed Generation.' All requirements are to be met prior to

the CUMING COUNTY PPD 'Witness Test' outlined in the agreement (Please allow sufficient time for CUMING COUNTY PPD review prior to witness testing). Where any of the following items/tests have been performed at a pre-approved packaged paralleling equipment manufacturer's facility prior to shipping, documentation supporting this testing must be submitted (may accept the documentation in such cases, or may require factory tests be repeated at the installed equipment location). The DG Owner or representative must complete all preoperational tests not performed by the factory (or factory tests repeated at the installed location). Such tests must be documented, and if above 25 kW (total DG capacity) must require the certification of a professional electrical engineer registered in the state where the project is being constructed. The required items/tests are:

- CUMING COUNTY PPD approved relay/device settings with any corresponding calculations and test points are to be in the possession of CUMING COUNTY PPD.
- CUMING COUNTY PPD approved AC and DC elementary drawings showing protective relay/device wiring connections are to be in the possession of CUMING COUNTY PPD.
- All protective relays/devices must have been electrically tested and calibrated according to the relay/device manufacturer's instruction manual.
- All protective relays/devices must have the CUMING COUNTY PPD-approved settings installed and proven using the submitted test point information to simulate fault conditions. These tests must also trip the interconnection breaker (load is not required on the breaker) to prove each DG trip path.
- A final, organized copy of all settings with test points must be in the possession of CUMING COUNTY PPD and the DG Owner for use during future maintenance tests.
- Sensing instrumentation (current and voltage transformers) must be ratio checked, polarity checked, continuity tested, and have the insulation integrity tested.

INSURANCE

Customer-generators shall provide proof of \$1,000,000 general liability insurance for the generating device and all associated equipment including but not limited to the net metering device and any disconnect switch, collective ("Device"). The policy must provide coverage for potential bodily harm, injury or death caused to Cuming County Public Power District employees and to third-parties. The policy must also provide coverage for all other damages that could be caused by the use, failure, or potential negligence associated with the use of the Device including but not

limited to property damage to Cuming County Public Power District's electric distribution system. Proof of this insurance coverage must be provided to Cuming County Public Power District prior to interconnection and shall remain in effect for the duration of the interconnection with Cuming County Public Power District's primary voltage distribution system.

REFERENCES

[Application For CUMING COUNTY PPD Approval To Construct Distributed Generation \(DG\) Interconnection.](#)
[CUMING COUNTY PPD Agreement for Closed Transition Operation of Distributed Generation.](#)
IEEE 1547 'Standard for Interconnecting Distributed Resources with Electric Power Systems'.
IEEE 1547.1 'Interconnection System Testing'.

ATTACHMENT 1

GLOSSARY

Accredited Generation: Generation capability recognized as meeting requirements for 'accreditation' established by the regional regulating authority charged with regulation of power transactions between utilities and independent power producers. Most generation installed primarily for the export and sale of electrical power (typically DG Class III facilities) meet this definition. See 'Non-Accredited Generation'.

Cogeneration: The concurrent production of electricity and heat, steam or useful work from the same fuel source.

Closed Transition: For the purpose of this standard, it is operation of two or more separate electrical generation sources while their outputs are tied together—see 'Parallel.'

Closed Transition Transfer: In this scheme, a facility's load is transferred from Source 1 to Source 2 and vice-versa while momentarily connecting the two sources together in 'closed transition.' The facility's load is not interrupted during the transfer process.

Current Transformer (CT): A transformer intended for metering, protective or control purposes, which is designed to have its primary winding connected in series with a circuit carrying the current to be measured or controlled. A current transformer normally steps down current values to safer levels. A CT secondary circuit must never be open circuited while energized.

DEC: Direct Energy Converter—see 'Generation Equipment.'

Direct DC Tripping: The wiring from the trip output contacts of the protective relay(s) must be connected directly to the trip coil of the interconnection circuit breaker, such that the protective relay alone can initiate a trip of the breaker. The trip circuit path for utility protection must not pass through (or be dependent upon) the contacts of a computer, PLC, or other foreign intelligent device not installed for the sole purpose of protection. Test switches, 94/auxiliary tripping relays, and 86/lockout relays are allowed in the trip circuit and are not considered foreign to the protection system. A by-product of direct DC tripping is all relay targets are functional as intended by the relay manufacturer.

DG: Distributed Generation. Includes all types of electric generation equipment. This standard is concerned only with DG capable of operating in closed transition (see ‘Parallel’) with the system.

Export: To supply power to the electric utility from distributed generation (DG)—the DG facility ‘exports’ power to the utility.

Export-only: Operation of a DG in closed transition with the utility, in which the entire capacity (or nearly the entire capacity) of the DG facility generation equipment is used for intentional ‘export’ back into the utility system. This definition would most often apply to Class III DG interconnections.

Import/Export: Two-way power transfer between the utility and a DG facility while operating in closed transition. The direction of power transfer is usually dependent upon the level of DG facility load and the level of DG output. If the DG facility generation is not operating, the facility may be importing power from the utility to serve facility load. If the DG facility generation is operating but not generating more than the DG facility load, the facility is still importing utility power. If the DG facility generation is generating power in excess of the DG facility load, the excess power is exported to the utility.

Import: To accept power from the electric utility in the traditional fashion to serve customer load—the customer ‘imports’ power from the utility.

Import-only: Operation of a DG facility in a closed transition with the utility in which any excess DG capacity is not allowed to be exported to the utility. Note in some cases the DG capacity may be low relative to the DG facility load, or the DG capacity may exceed the DG facility load, but at no time is power allowed to be intentionally ‘exported’ back to the utility.

Interconnection Breaker: See the ‘Protective Equipment’ section in this standard.

Interconnection Disconnect: See the ‘Protective Equipment’ section in this standard.

IPP: Independent Power Producer.

Island or Islanding: For the purposes of this standard, it is the undesirable condition where the

‘normal’ utility electrical source has been disconnected from and no longer serves all or part of a utility circuit, and all or part of the utility circuit load is being served for an extended period (beyond a few seconds) by a DG facility. Such a circuit is operating as an electrical ‘island,’ independent from the utility.

Network, Grid: For the purpose of this standard, it is defined as a configuration of the distribution system where the secondary windings of multiple distribution transformers are tied in parallel, while the transformer primaries are served from more than one distribution circuit. Each transformer secondary is protected using a ‘network protector’. Multiple customers tap into the same secondary connection, usually at 208V or 480V, three-phase.

Network, Spot: See ‘Network, Grid’ above. For the purpose of this standard, the ‘Spot’ network is essentially the same as a ‘Grid’ network, but the ‘Spot’ network serves only one customer facility.

Non-Accredited Generation: Generation which is not ‘accredited’ by the regional regulating authority charged with regulation of power transactions between utilities and other independent power producers. Most generation installed primarily for local facility load support (and may have export capability) meet this definition. See ‘Accredited Generation’.

Open Transition: For the purpose of this standard, it is operation of two or more separate electric generation sources while their outputs are not tied together—they are operating separately from one another, with no electrical tie between the two or more systems (other than ground).

Open Transition Transfer: In this scheme, a facility’s load (or portion of it) is transferred from Source 1 to Source 2 and vice versa without momentarily connecting the two sources together. Here, the facility’s load is interrupted momentarily during the transfer process. Typical emergency standby system automatic transfer switches are open transition type.

Parallel: Operation of DG in closed transition (tied together) with the utility electrical system. Operation in parallel implies the DG and utility sources are tied together electrically, are operating at matching phase rotation with closely matching voltage and frequency, and the DG and utility are synchronized with each other. The DG facility may be importing or exporting power from the utility during parallel operation. Operation of DG in open transition (not tied together) with the utility electrical system is not parallel operation.

Peak Load: The maximum electric load consumed or produced in a stated period of time.

Peak Shaving: Generation operation which results in reducing a facility’s peak load (as seen by the utility) or demand.

Point of Common Coupling (PCC): (IEEE P1547 draft 4) The connection point on an electric power system where the electric system is intentionally connected to a public transmission and/or distribution system and at which point performance requirements are defined.

Potential Transformer (PT): A transformer intended for metering, protective or control purposes, which is designed to step down voltage values to safer levels.

Reclosing/Automatic Reclosing: A common utility practice, it is an attempt to quickly restore electric service to de-energized overhead power lines by re-applying power to the line very soon (0.33 to 5 seconds) after the line has cleared (become de-energized) due to a fault. In sequence: a fault occurs on a line, all line breakers open to clear the fault (de-energizing the line), after a brief delay line breaker(s) close (to re-energize the line), and the line is returned to service. This practice is based on the fact most faults on utility overhead electric lines are of a temporary nature, and as such, the line is clear of faults and ready to be re-energized almost immediately after the fault event.

SPC: Static Power Converter—see ‘Generation Equipment’ in this standard.

Synchronism: Expresses the condition across an open circuit wherein the voltage sine wave on one side matches the voltage sine wave on the other side in frequency and amplitude without phase angle difference.

Utility Grade Relaying: Relays meeting IEEE/ANSI 037.90 design standards. Generally such devices are designed first and foremost for use as a utility protective relay, are for high-speed use, meet utility standards for construction, and are the product of a recognized utility relay manufacturer.

Wheeling: The use of transmission or distribution facilities of utility (or utilities) B to transmit power from utility (or DG facility) plant A to utility (or customer) C load.

21: Distance function. The distance relay function operates when the circuit impedance, reactance, or admittance increases or decreases beyond a predetermined value. This relay function is not a standard interconnection relay requirement but may be required by CUMING COUNTY PPD in certain situations.

25: Synchronism or synchronism check function. The function operates to close a breaker when two AC sources are within the desired limits of frequency, phase angle, and voltage to permit or cause the paralleling of the two sources.

27: Undervoltage function. This function operates for specified undervoltage conditions. An operation of this relay function usually results in a trip signal to the interconnection breaker(s).

32: Directional Power Relay/Reverse Power Function. The directional power relay operates on a desired value of real power flow (watts) in a given direction. This relay will initiate a trip signal once the reverse power setting is exceeded. The reverse power limit of this relay is typically set for the maximum export limit (plus a safety margin) for import-only or import/export installations.

46: Reverse-Phase or Phase-Balance Current Relay/Negative Sequence Overcurrent Function.

47: Phase-Sequence or Phase-Balance Voltage Relay/Negative Sequence Overvoltage Function.
Typical DG-side protection for phase sequence and from loss-of-phase.

50: Instantaneous overcurrent function.

50G/50N: Instantaneous ground/neutral overcurrent function.

51: Inverse time overcurrent function—often integral to the interconnection breaker.

51G/51N: Inverse time ground/neutral overcurrent function.

52: Circuit breaker (ac).

59: Overvoltage function—this function operates for specified overvoltage conditions. An operation of this relay function usually results in a trip signal to the interconnection breaker(s).

67: Directional overcurrent function—This relay function is intended to operate for a fault on the CUMING COUNTY PPD system and trip the interconnection breaker.

67G/67N: Directional ground/neutral overcurrent function—This relay function is intended to operate for a fault on the CUMING COUNTY PPD system and trip the interconnection breaker.

68: Out-of-step function.

81: Frequency function.

81O/U: Over/under frequency function—the frequency relay function operates for specified variances from the normal system frequency.

81R: Rate-of-change frequency function.

86: Lockout relay, either manually or electrically reset. Where references are made to lockout relays, they should be assumed to be manually reset unless indicated otherwise.

94: Auxiliary tripping relay.

Exhibit Documents

Outlined in exhibits below is a list of the documents required for installation of distributed generation on the CCPPD system and made a part of this manual. DG Operators are encouraged to contact CCPPD for any updated versions of these documents.

Exhibit A - Application to Construct Distributed Generation (DG) Interconnection

Exhibit B – Interconnection and Service Agreement

Exhibit C – Energy Purchase Agreement

Exhibit D - Avoided Cost Rate Schedule(s) CCPPD Small Distributed Generation Rate Schedule

Disclaimer: The Board of Directors of Cuming County Public Power District reserves the right to amend or rescind these policies, procedures, exhibits and rates at anytime.

Date Created: 10/14/15